

Accessory	Application	Publications No.
FRONT UNDER SPOILER	2005 RL	BII 27201
		Issue Date
		MAY 2005

PARTS LIST

Front under spoiler

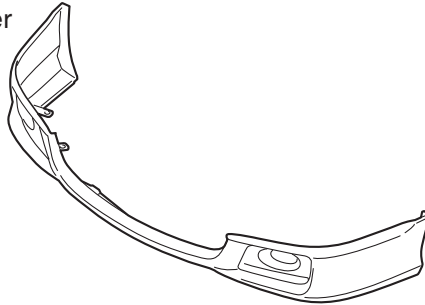

2 Square head bolts

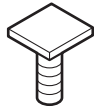

5 Washer-nuts



4 Self-tapping screws

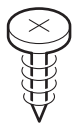

4 Spring nuts



3 Stepped bolts



2 Clips



Template

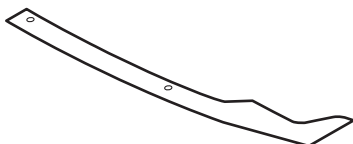

TOOLS AND SUPPLIES REQUIRED

- Phillips screwdriver
- Flat-tip screwdriver
- Stubby Phillips screwdriver
- Ratchet
- 10 mm Socket
- Shop towel
- Masking tape
- Isopropyl alcohol
- Drill
- 3 mm, 6 mm, 8 mm and 10 mm Drill bits
- 12 mm Hole saw
- Pushpin
- File
- Eye protection (face shield, safety goggles, etc.)
- Utility knife
- Hacksaw
- Felt-tip pen
- Blanket
- Scale

INSTALLATION

Customer Information: The information in this installation instruction is intended for use only by skilled technicians who have the proper tools, equipment, and training to correctly and safely add equipment to your vehicle. These procedures should not be attempted by “do-it-yourselfers.”

NOTE:

- Be careful not to damage the body paint finish.
- This front under spoiler kit should only be installed if the ambient air temperature is 60°F (15°C) or above.
- To allow the adhesive to “cure”, do not wash the car for 24 hours.

1. Open the hood. Disengage one pin each of the left and the right fender trim from the grille cover.

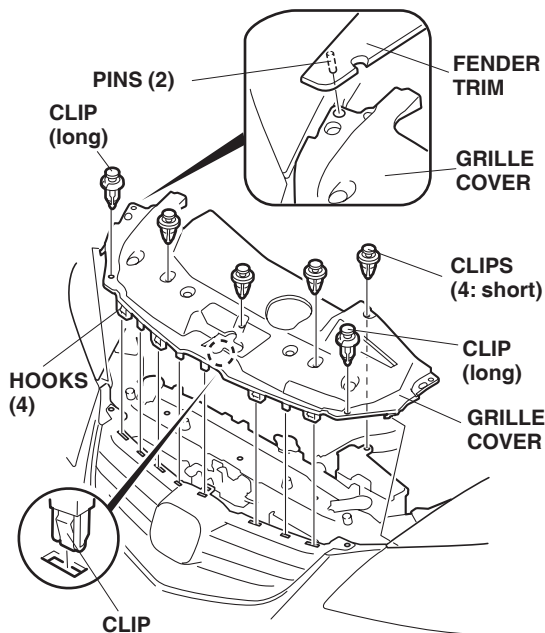

2. Remove the two clips (long) and the four clips (short) from the grille cover. Disengage the clip and the four hooks, then remove the grille cover.

3. Remove the four clips (long), four clips (short), four bolts and two self-tapping screws that fasten the front bumper. Disconnect the three vehicle connectors, remove the front bumper, and set it on a blanket.

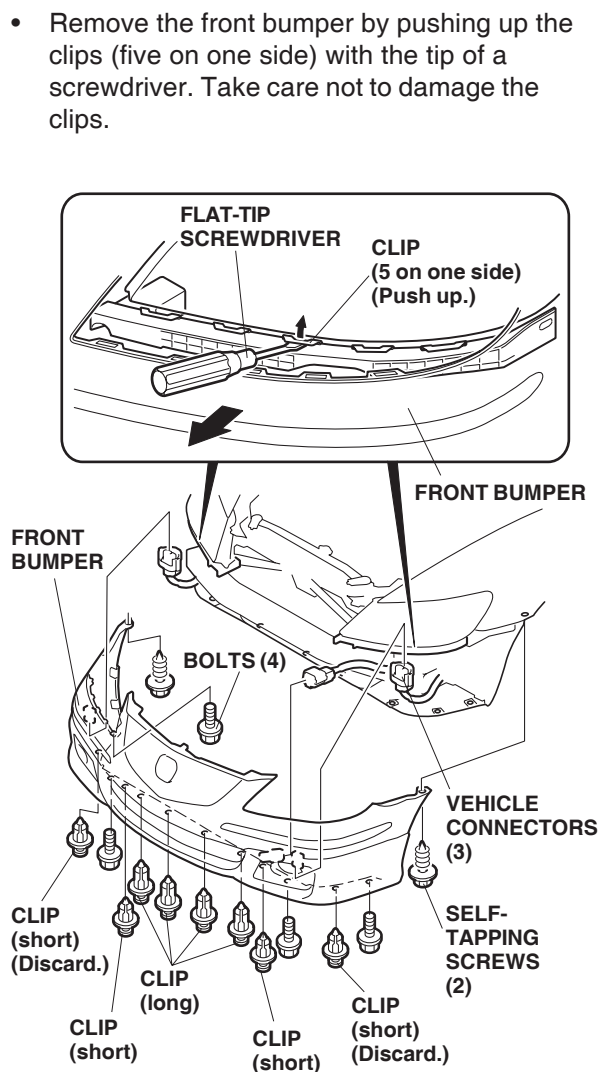

- Remove the left front bumper protector from the front bumper (one clip and ten hooks in order of the outer hooks first, then the inner hooks).

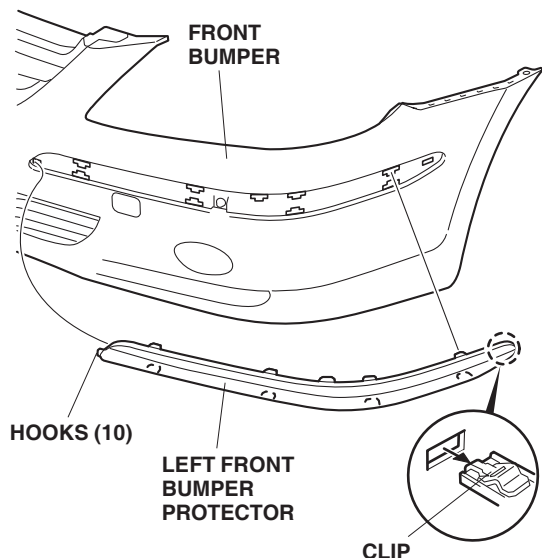

- Remove the clip, that secures the outside air temperature sensor connector, from the left fog light bracket. Remove the outside air temperature sensor and harness from the front bumper (two clips).

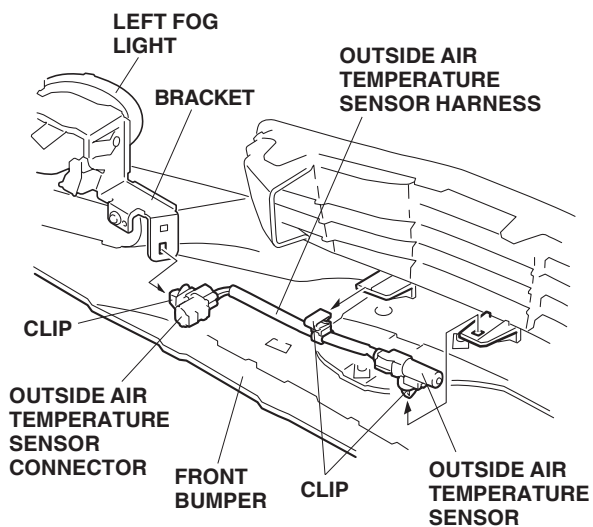

- Remove the left fog light from the front bumper (three self-tapping screws).

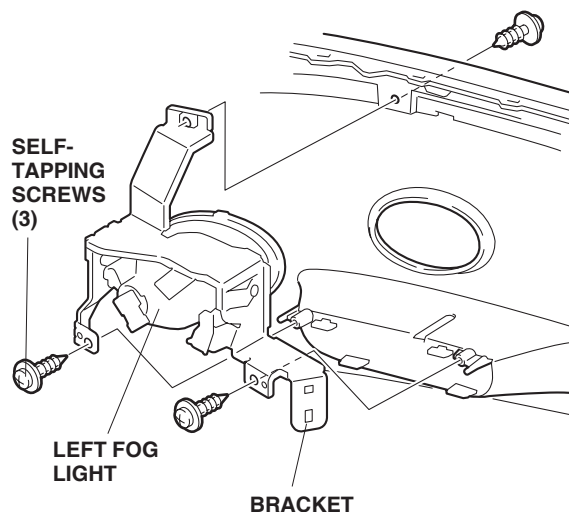

- Repeat steps 4 and 6 on the right side of the front bumper.
- Slide the safety plate toward you and remove it from the front bumper (two bolts).

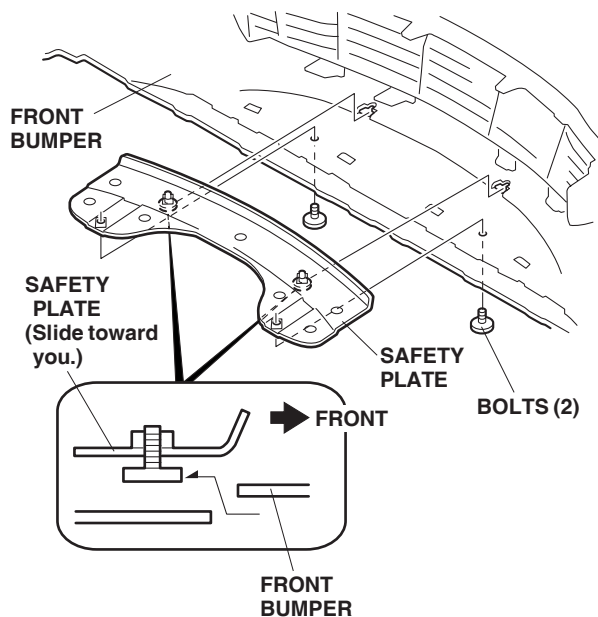

- Position the template on the front bumper by aligning the end of the template with the left and bottom ends of the front bumper. Using a pushpin, Pierce the front bumper as indicated on the template.

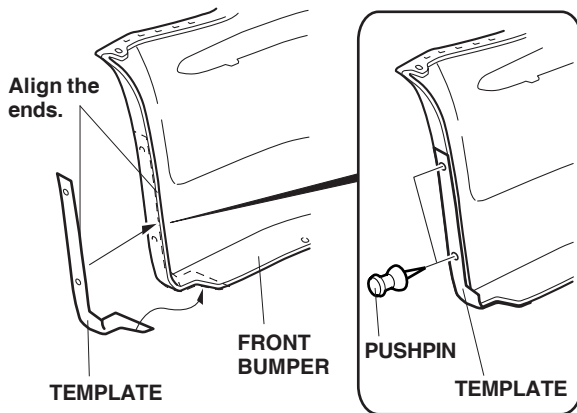

- Repeat step 9 on the right side of the front bumper.
- Using a pushpin, pierce through the five scribe marks on the front and bottom of the front bumper.

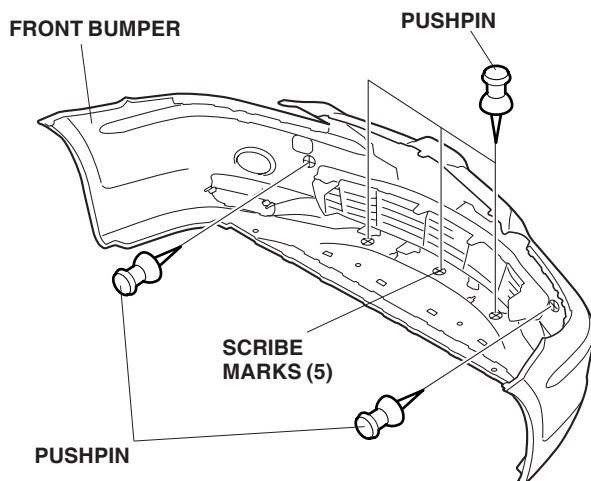

- While wearing eye protection, drill a 6 mm hole at each of the four marks on both ends of the front bumper, and drill an 8 mm hole at each of the two marks on the front side of the front bumper.

- First drill all of the marks with a 3 mm drill bit.
- Drill through the four holes at the right and left ends of the front bumper with a 6 mm drill bit.
- Drill through the holes in the front side of the front bumper with an 8 mm drill bit.
- Using a file, remove any burrs from the holes.

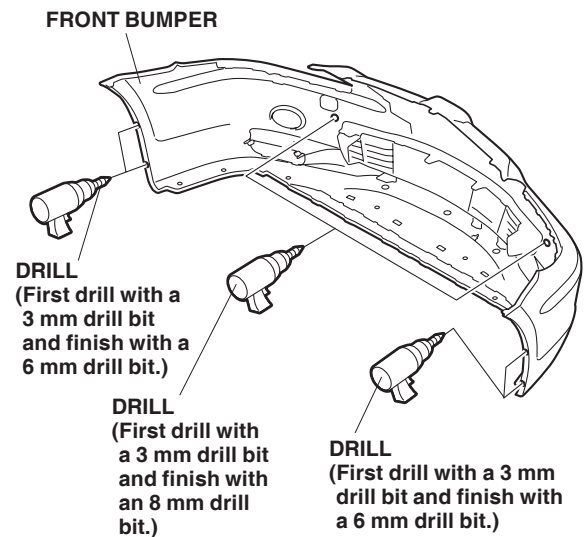

13. While wearing eye protection, drill a 10 mm hole through the center mark out of the three marks on the bottom of the front bumper. Drill a 12 mm hole through each of the remaining two marks.
 - First drill all of the marks with a 3 mm drill bit.
 - Drill through the center hole with a 10 mm drill bit.
 - Drill through the remaining holes with a 12 mm hole saw.
 - Check that the 10 mm hole is drilled in the center of the mark. If a hole is not in the center of the mark, correct.
 - Using a file, remove any burrs from the holes.

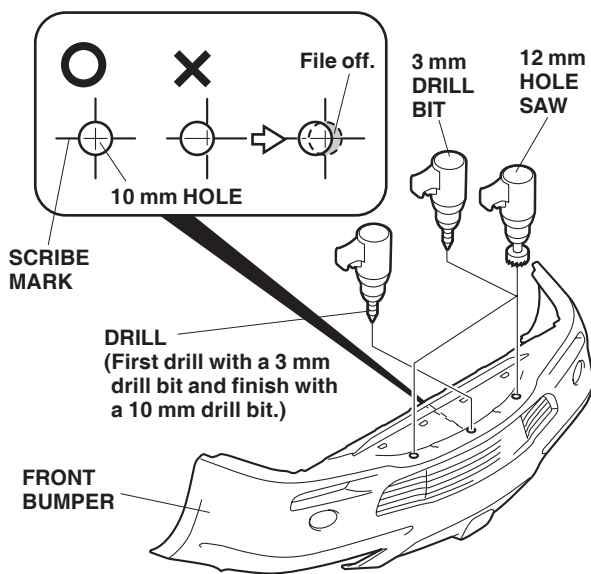

14. Mark the front bumper at the two points 10 mm inside from the two inner scribe marks out of the four marks that locate around the fog light opening in the front bumper. Pierce a pushpin through the marks you just made.

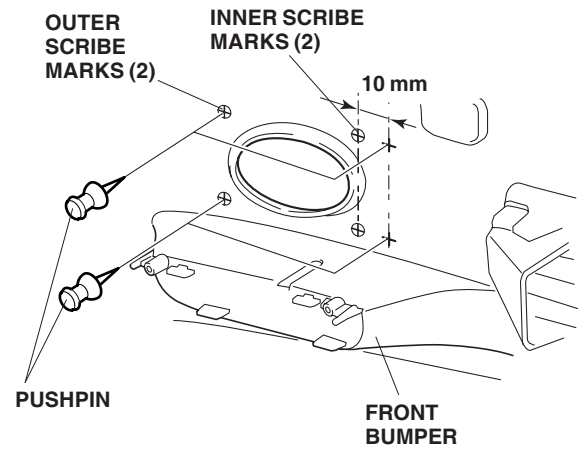

15. Pierce a pushpin through the two outer scribe marks.
16. While wearing eye protection, drill a 10 mm hole through each of the four marks.
 - First drill with a 3 mm drill bit and finish with a 10 mm drill bit.

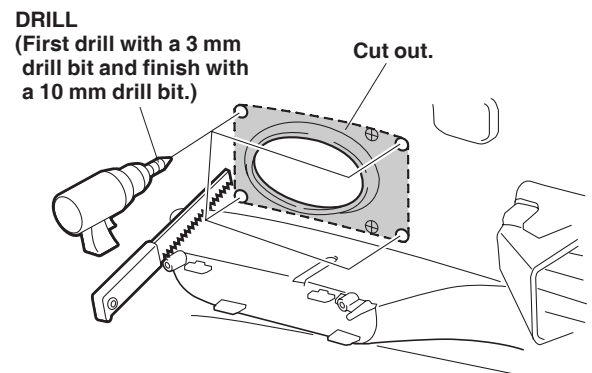

17. Draw the lines that pass the outer edge of each hole you just made. Cut out the front bumper along the lines and remove the burrs from the edges of the hole.
18. Repeat steps 14 through 17 on the right side of the front bumper.

19. Measure the left front inner fender from the line on the inner fender as shown, and mark at each measurement point. Cut the inner fender at each marked point and bend the cut parts forward as shown.

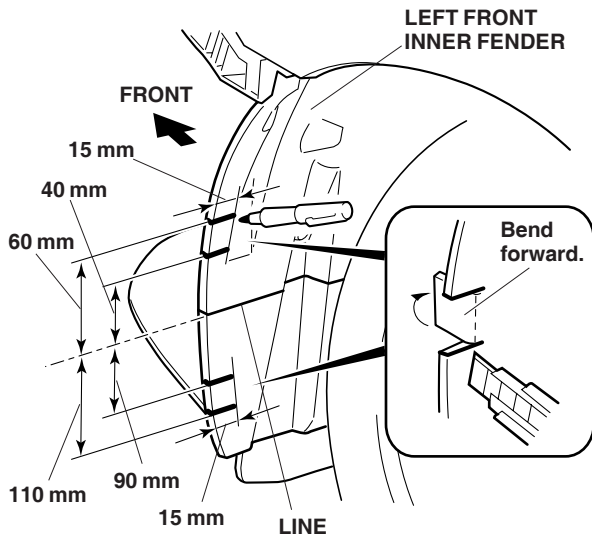

20. Repeat step 19 on the right side of the front inner fender.
21. Install the two square bolts on the front under spoiler.

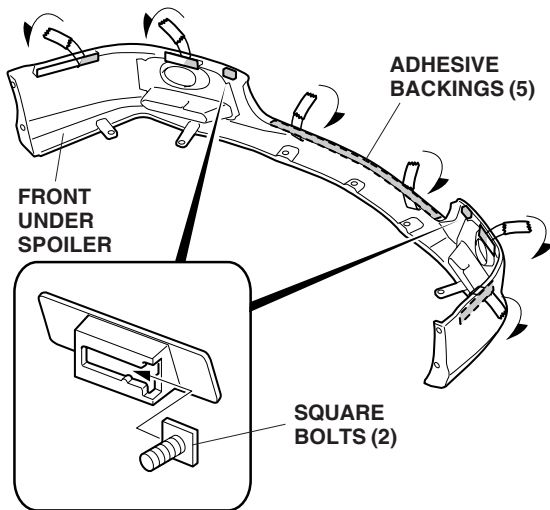

22. Using isopropyl alcohol on a shop towel, thoroughly clean the front bumper where the front under spoiler will attach.
23. Attach a strip of masking tape to the end of each adhesive backing and remove 20 to 30 mm of the adhesive backing. Fold the ends back, and tape them to the front of the spoiler.

24. Slide the four spring nuts onto both ends of the front bumper.

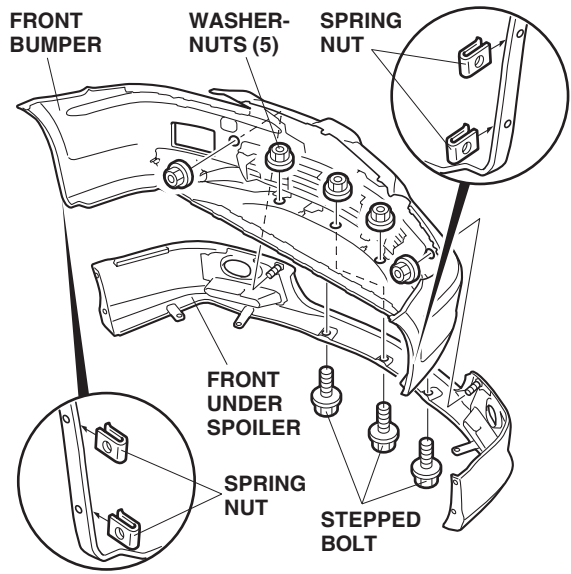

25. Reinstall the safety plate, the right and left fog lights and the outside air temperature sensor.
26. Position the front under spoiler on the front bumper and install the five washer-nuts and three stepped bolts.
27. Connect the three vehicle's connectors and reinstall the front bumper using the four clips (long), two clips (short), four bolts, two self-tapping screws and two clips (supplied).

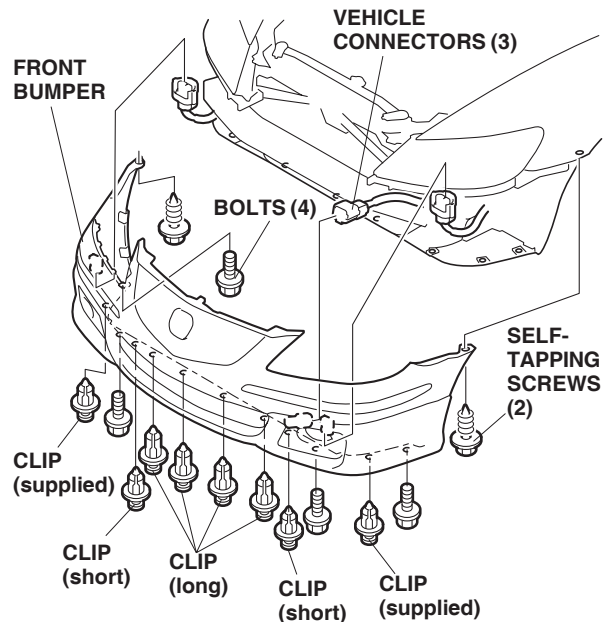

28. Install the four self-tapping screws on both ends of the front under spoiler.

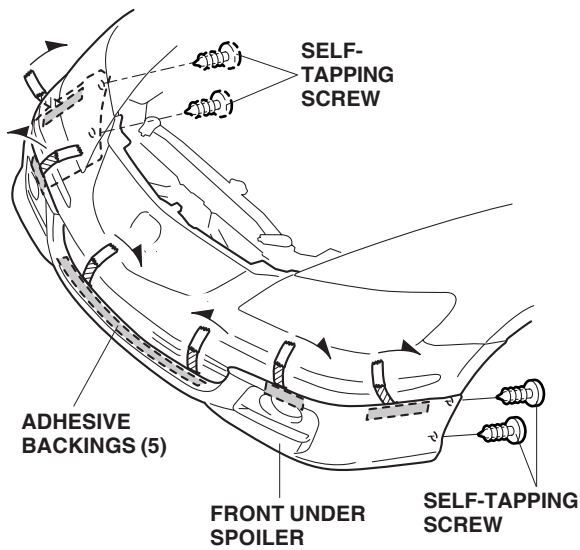

29. While holding light pressure on the spoiler, carefully remove the adhesive backings. Hold the spoiler firmly against the front bumper with palm of your hand for 30 seconds.
30. Reinstall the grille cover.