

Accessory	Application	Publications No.
TRUNK SPOILER	2005 RL	BII 27035-29095
		Issue Date
		MAY 2005

PARTS LIST

Trunk spoiler

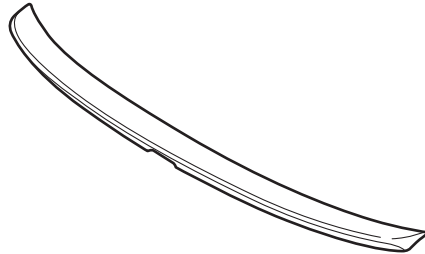

Right support strut

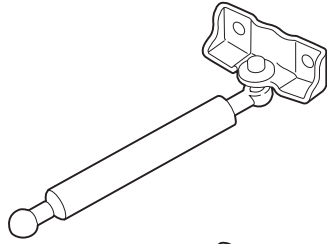

Left support strut

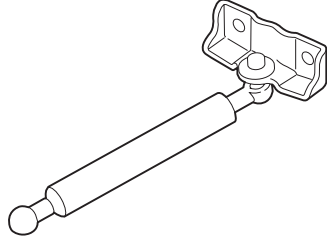

4 Washer-bolts



4 Adhesive seals



2 Marking tape sheets

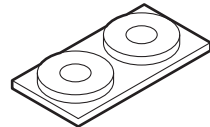

Template

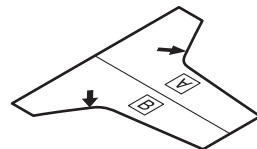

2 Stud balls

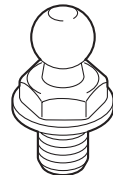

TOOLS AND SUPPLIES REQUIRED

- Eye protection (face shield, safety goggles, etc.)
- Drill
- 3 mm and 8 mm Drill bits
- File
- Center punch
- Touch-up paint
- Ratchet
- 10 mm Socket
- Torque wrench
- Masking tape
- Felt-tip pen
- Shop towel
- Isopropyl alcohol
- Blanket
- 12 mm Combination wrench
- Rubber hammer

INSTALLATION

Customer Information: The information in this installation instruction is intended for use only by skilled technicians who have the proper tools, equipment, and training to correctly and safely add equipment to your vehicle. These procedures should not be attempted by “do-it-yourselfers.”

NOTE:

- Be careful not to damage the body paint finish.
 - This trunk spoiler kit should be installed only if the ambient air temperature is 60°F (15°C) or above.
1. Make sure you have the anti-theft codes for the radio and navigation system, then write down the radio presets.
 2. Disconnect the negative cable from the battery.

Installing the Trunk Spoiler

3. Open the trunk lid. Remove the right and left lid cushions (three clips each).

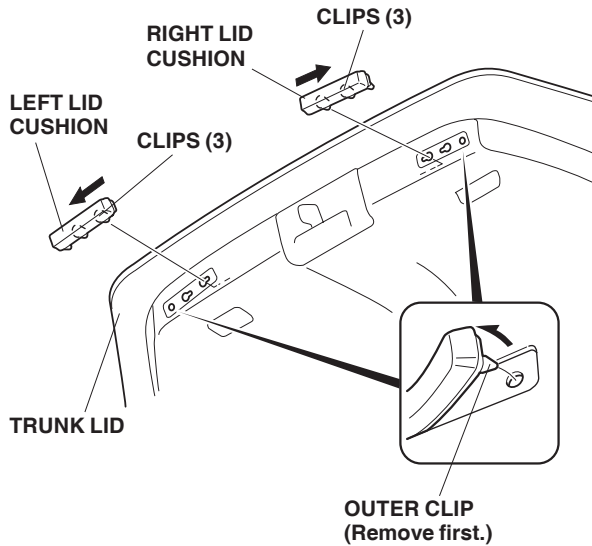

4. Remove the trunk light (one tab and disconnect the connector).

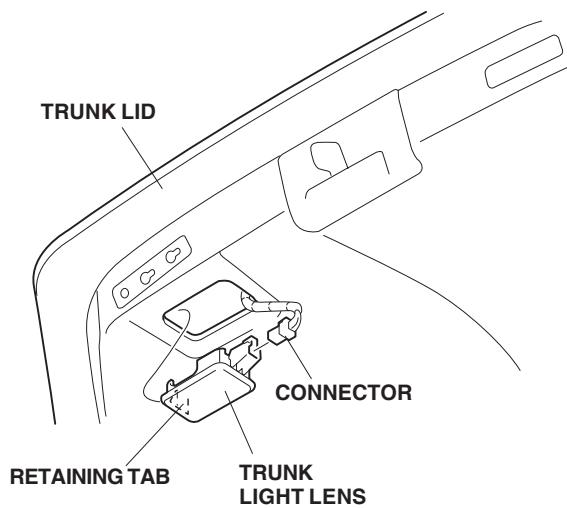

5. Remove the trunk lid trim (eight clips).

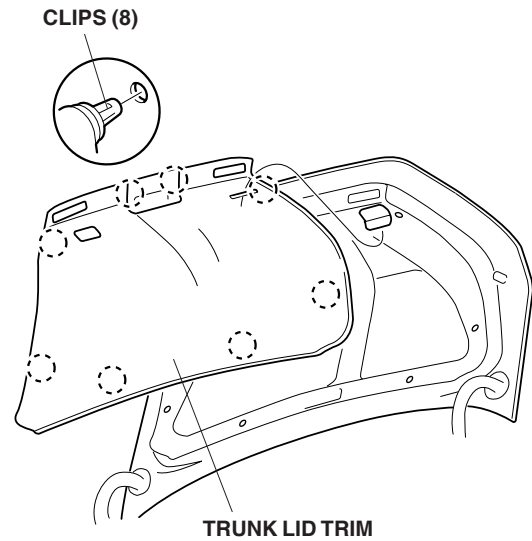

6. Close the trunk lid. Position the spoiler on the trunk until the gap between the edge of the trunk lid and the edge of the spoiler is equal on both sides. Position the spoiler so that the gap between the spoiler and "A" emblem is equal. Using strips of masking tape, mark the trunk lid on each side. Remove the spoiler.

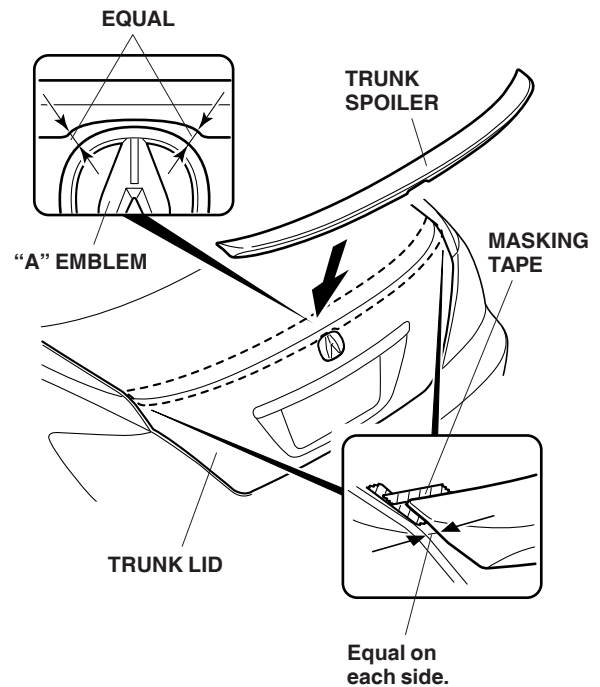

- Remove the marking tapes from the marking tape sheets, and attach one marking tape over each threaded hole on the spoiler.

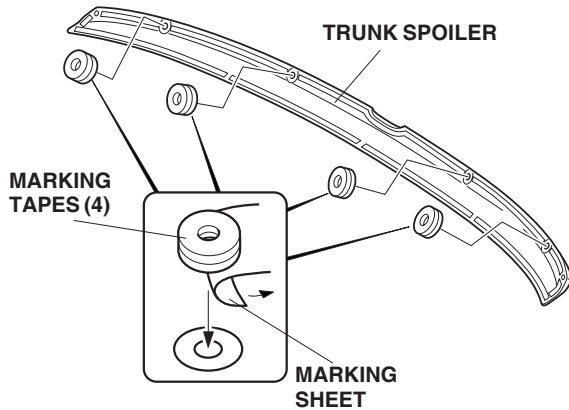

- Remove the other adhesive backing from the four marking tapes. Do not remove the yellow tape adhesive backing.

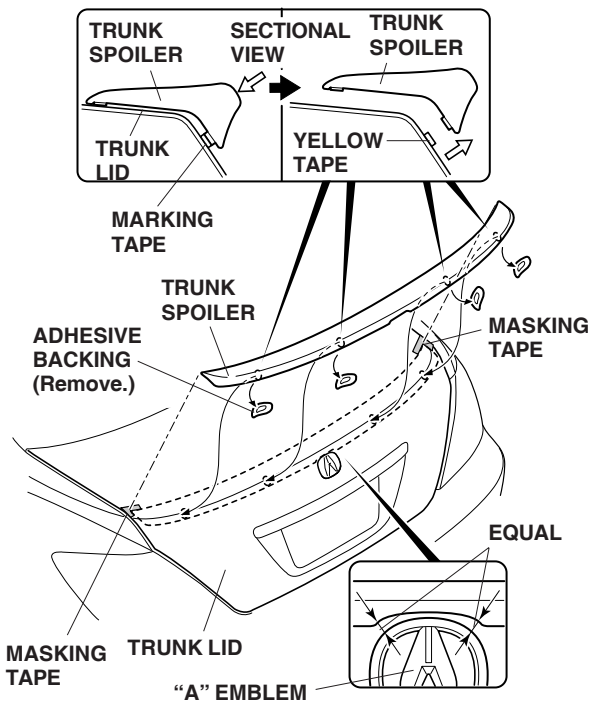

- Position the spoiler on the trunk lid, aligning the edge of the spoiler with the masking tape you installed in step 6. Check that the gap between the spoiler and "A" emblem is equal. Firmly push the spoiler against the trunk lid until the yellow tape transfers onto the trunk lid.
- Gently lift the spoiler from the trunk, and confirm that the yellow tape transfers to the trunk lid.

- Vertically align template A (INNER) on the trunk lid at the center of the inboard yellow tape, and mark the horizontal point as indicated by the arrow on the template.
- Flip the template, and vertically align template B (OUTER) on the trunk lid at the center of the outboard yellow tape, and mark the horizontal point as indicated by the arrow on the template.

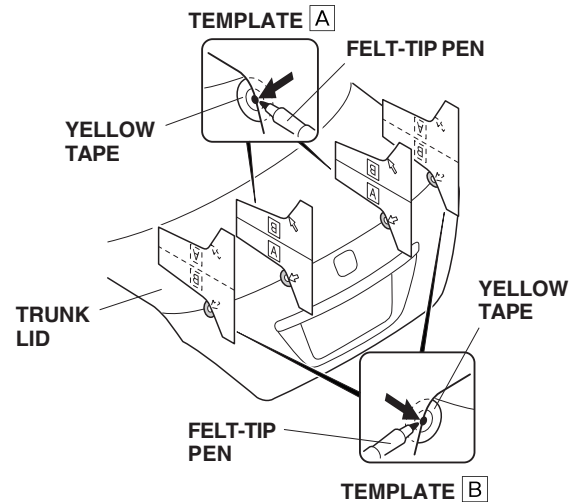

- Remove the yellow tape from the trunk lid.

NOTE: If the yellow tape is not removed, the spoiler will sit unevenly and or leave unnecessary gaps between the trunk lid and spoiler.

14. While wearing eye protection, lightly center-punch the marks and drill four 8 mm holes through the marks you made:

- Place a blanket in the trunk to catch any metal shavings.
- Using a drill stop on the end of each bit, first drill with a 3 mm drill bit, and finish with an 8 mm drill bit.
- Remove any burrs from the edges of the holes with a file, and apply touch-up paint on both sides of the holes. Allow the touch-up paint to dry before you proceed to the next step.
- Remove the blanket and any metal shavings.

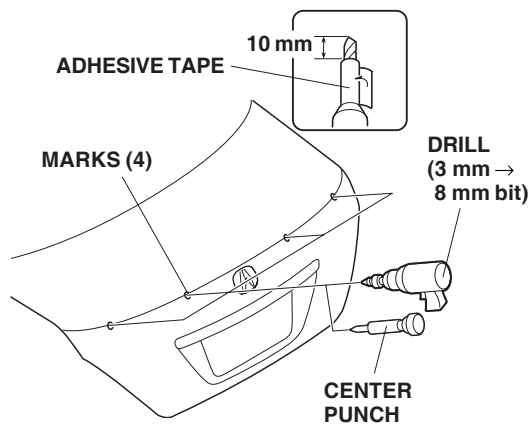

15. Remove the marking tape from the inside of the trunk spoiler.

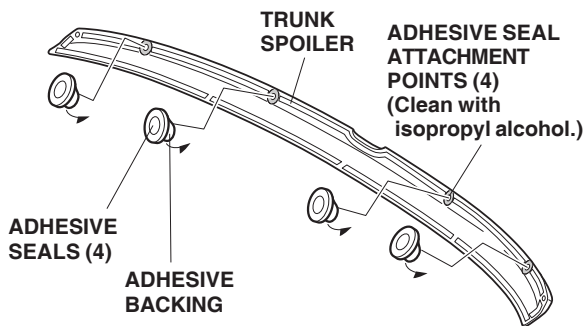

16. Using isopropyl alcohol on a clean towel, wipe the spoiler where the marking tapes were attached.

17. Remove the adhesive backing from the four adhesive seals, and attach the seals over the holes in the trunk spoiler.

18. Using isopropyl alcohol on a shop towel, thoroughly clean the area where the trunk spoiler will attach.

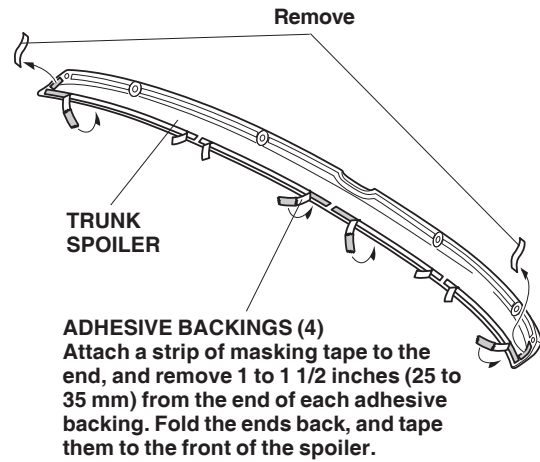

19. On the inside of the spoiler, attach a strip of masking tape to the ends of the adhesive backings and remove 1 to 1 1/2 inches (25 - 35 mm) of the adhesive backing. Fold the ends back, and tape them to the front of the spoiler. On each end remove the small strip of adhesive backing.

20. Align both edges of the trunk spoiler with the masking tapes on the trunk lid, and install the four washer-bolts. Do not tighten the washer-bolts at this time.

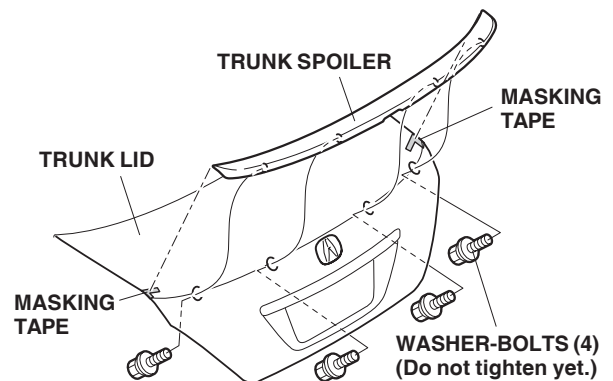

21. When the trunk spoiler is aligned properly with the trunk lid, carefully remove the adhesive backing on each side. After removal of the adhesive backings, apply sufficient pressure to the entire surface.

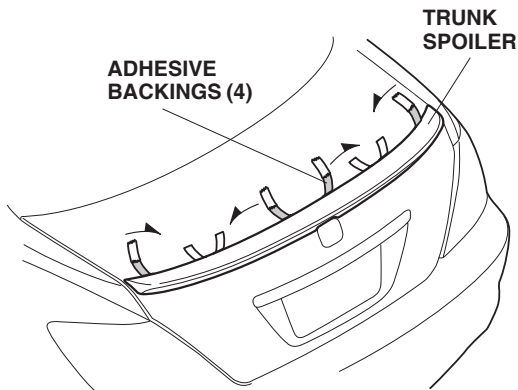

22. Open the trunk lid, and torque the four washer-bolts to 8.8 N·m (0.9 kgf·m, 6.5 lb-ft)
23. Remove the masking tape on the trunk lid.

Installing the Open Stay

24. Remove the spare tire lid from the trunk.

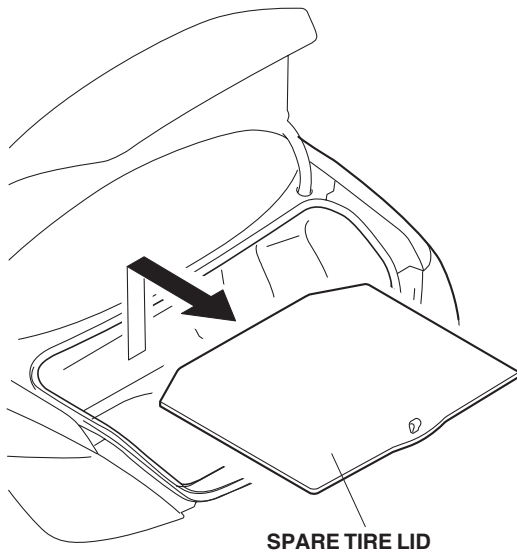

25. Remove the weatherstrip, and remove the rear trim panel (two retaining tabs and four clips).

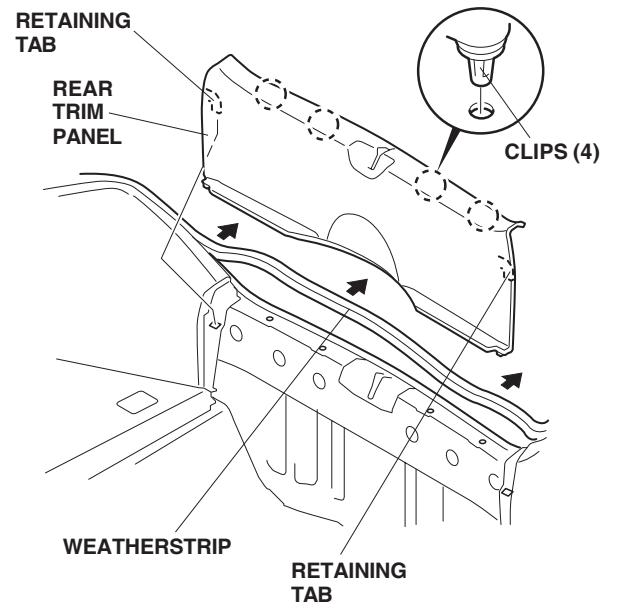

26. Turn over the trunk front trim panel (one clip).

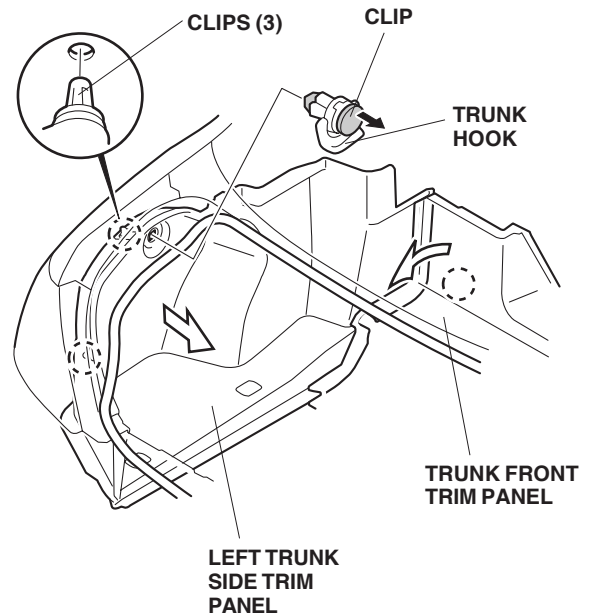

27. Remove the trunk hook (clip).
28. Turn over the left trunk side trim panel (two clips).

29. Remove the trunk light (one tab and disconnect the connector).

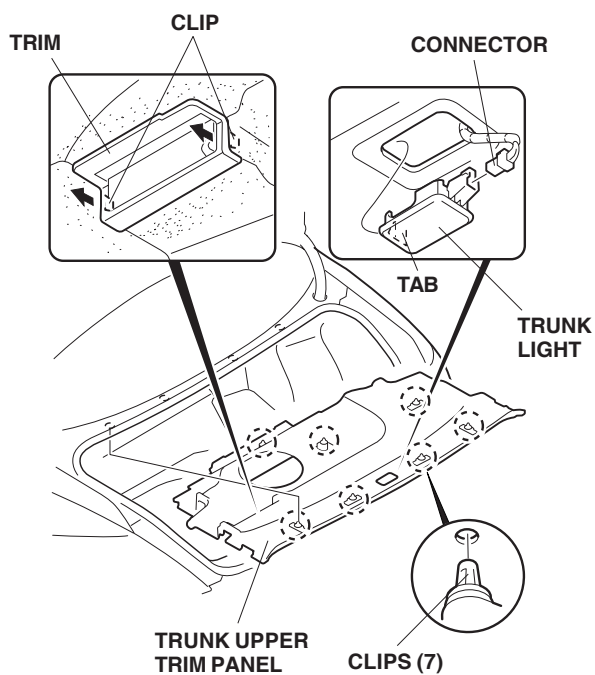

30. Remove the trunk upper trim panel (seven clips and two clips on the trim).

31. Remove the two bolts securing the trunk lid support strut bracket on the left side of the vehicle.

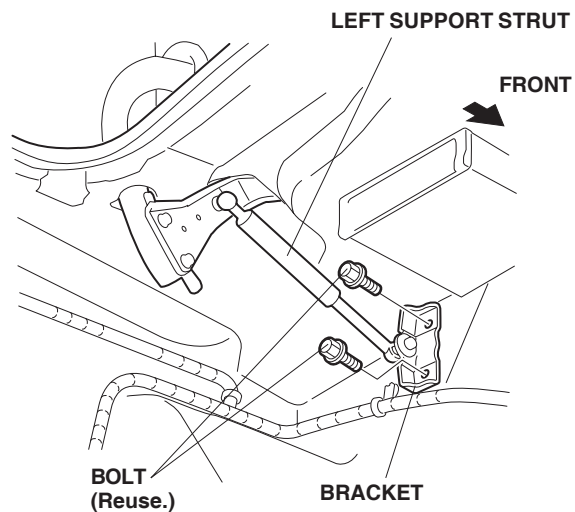

32. With an assistant holding the trunk lid, remove the support strut by removing the stud ball. Open the trunk lid halfway to facilitate removal of the stud ball.

NOTE: Do not use pliers or vise grips to hold the trunk lid up while installing the struts.

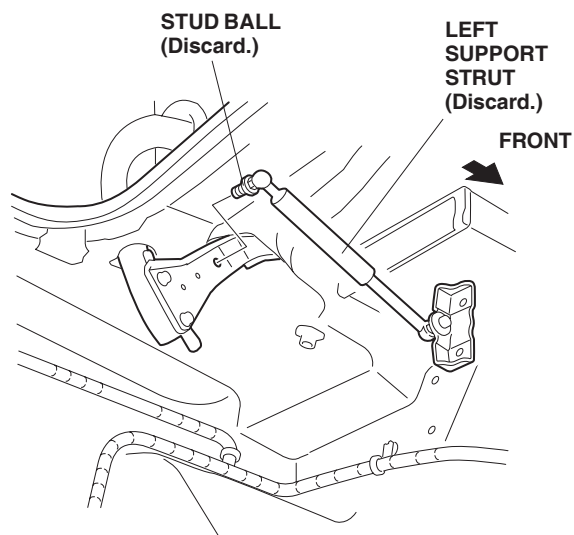

33. Install the new stud ball on the trunk hinge arm. Tightening torque: 10 N·m (8 lb-ft).

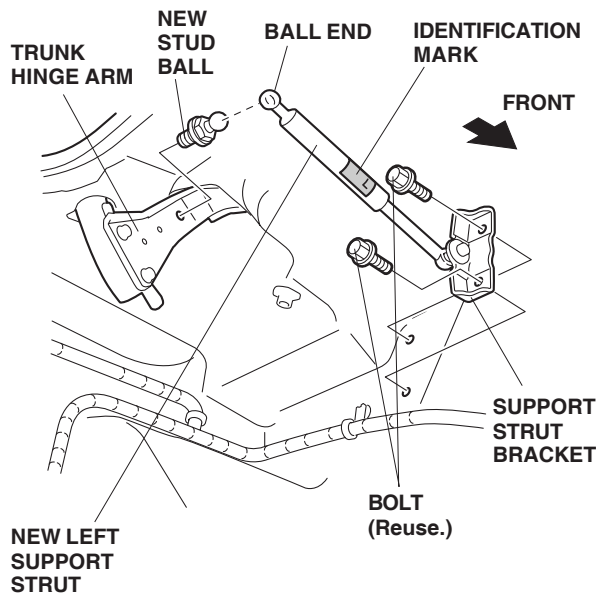

34. Confirm the identification mark of the support strut and then install the new left support strut bracket with the two bolts.
35. Install the support strut on the stud ball by lightly tapping on the ball end with a rubber hammer.
36. Repeat steps 26 thru 28, and 31 thru 35 on the right side of the vehicle.
37. Reinstall all removed parts. Check that all clips are installed securely.
38. Reconnect the negative cable to the battery.
39. Enter the anti-theft codes for the radio and navigation system, then enter the customer's radio presets.
40. Reset the clock.
41. Open the trunk lid, and make sure the trunk lid stays open on its own.

42. Do the PCM idle learn procedure.
- Make sure all electrical items are turned off.
 - Start the engine. Hold the engine speed at 3,000 rpm with no load (in Park or Neutral) until the radiator fan comes on.
 - Let the engine idle for about 10 minutes with the throttle fully closed and with all electrical items off.

NOTE: If the radiator fan comes on during this step, the time it is operating must not be included in the 10 minutes.

NOTE: Whenever the battery is disconnected, the driver's window AUTO function is disabled.

43. Start the engine. Push down on the driver's window switch until the window is fully open.
44. Pull up on the driver's window switch to close the window completely, then hold the switch for a second or two more.
45. Test the window AUTO function.

USE AND CARE

- Handle the spoiler with care. It is not designed to absorb impact.
- Do not open or close the trunk lid by grasping the spoiler.
- Check the spoiler mounting bolts periodically, and retighten them if necessary.